

Electrical Power Transmission & Distribution (DI03000101)



www.vishaldevdhar.org

Vishal D Devdhar

Lecturer

Electrical Engineering Department

Government Polytechnic Rajkot



Unit-4

A.C. Distribution System - Power Cable

What is Power Cable?

A power cable is an assembly used to transmit and distribute electrical energy.

- Consists of
 - Conductor
 - insulation
 - protective sheath.
- Used in
 - Residential
 - Commercial
 - Industrial systems

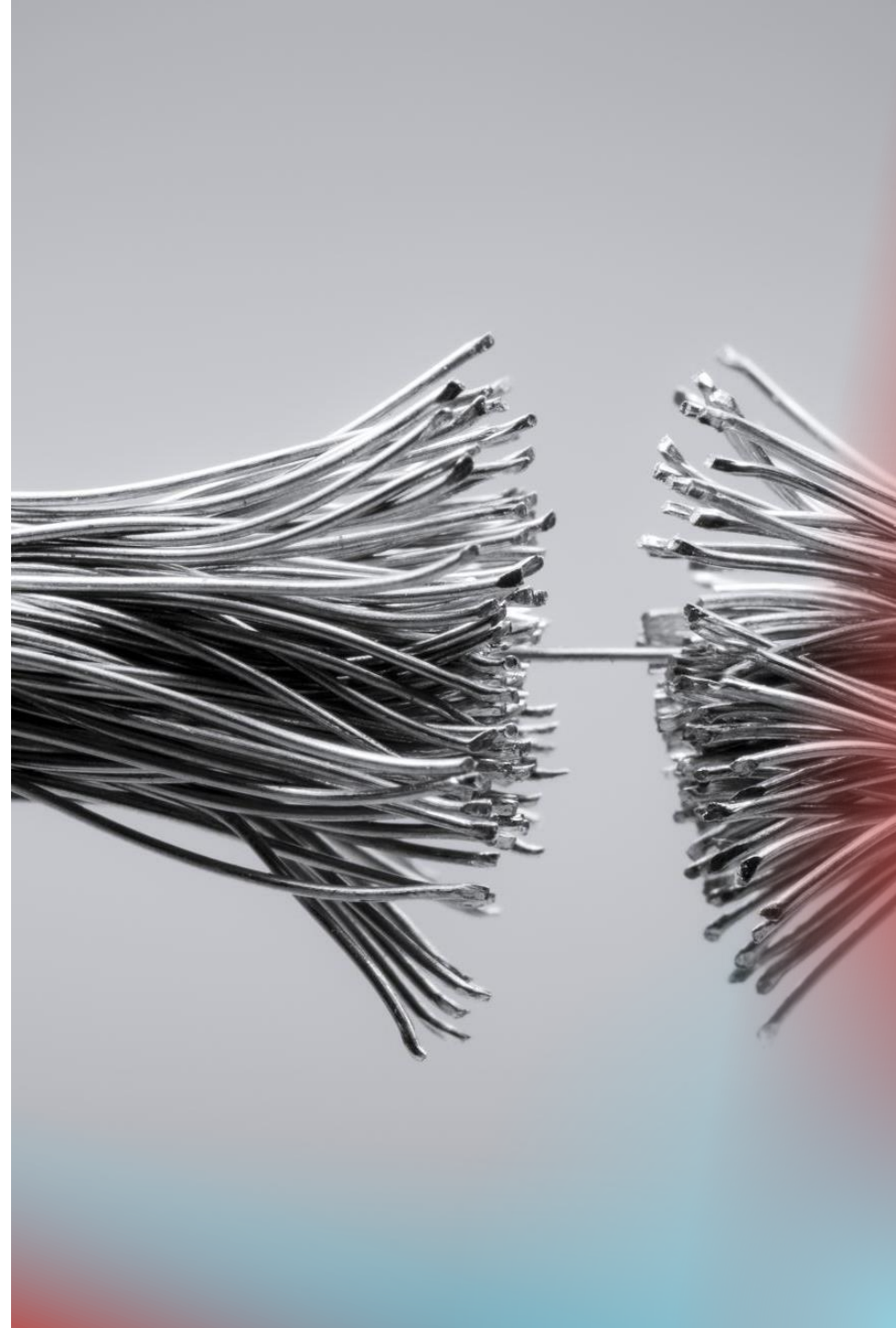

Requirements of Underground Cables

- Adequate Conductor Size
- Low Voltage Drop
- High insulation resistance
- Mechanical strength to withstand soil pressure
- Resistance to moisture, chemicals, and corrosion
- Thermal stability for current carrying capacity
- Long operational life
- Minimal maintenance

Advantages of Underground Cable

Aesthetic appeal (no overhead lines)

Reduced risk of electrical hazards

Less affected by weather conditions

Lower maintenance costs

Suitable for densely populated areas

Safe from vandalism

Disadvantages of Underground Cable

High initial cost

Difficult fault detection

Complex installation

Requires skilled labor

General Construction of Cable

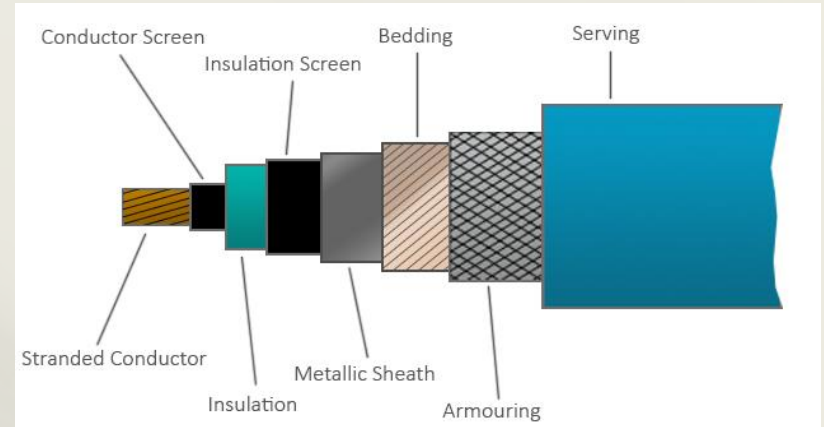
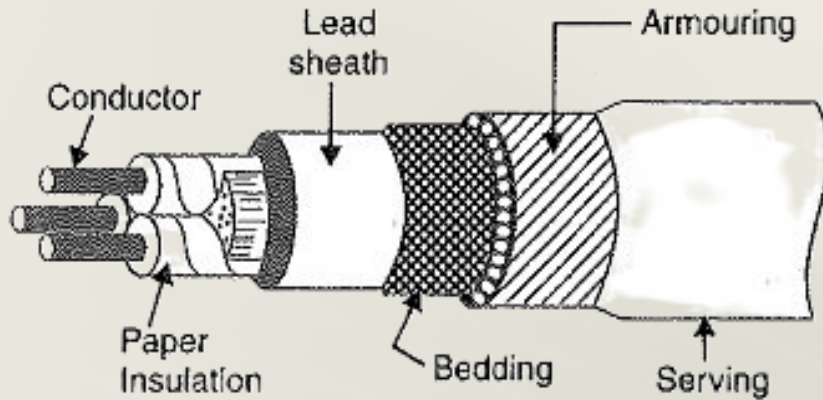

Core (conductor):
Carries current.

Stranded aluminum or
annealed copper

Insulation: Prevents
leakage.

Varnished cambric, vulcanized
bitumen, impregnated paper

Metallic Sheath:
Moisture protection.

Lead or aluminum for
moisture protection

Bedding: Cushioning.

Paper tape or fibrous
material

Armouring: Protection.

Galvanized steel wires for
protection

Serving: Outer layer.

Jute cloth for atmospheric
protection

CLASSIFICATION OF CABLES

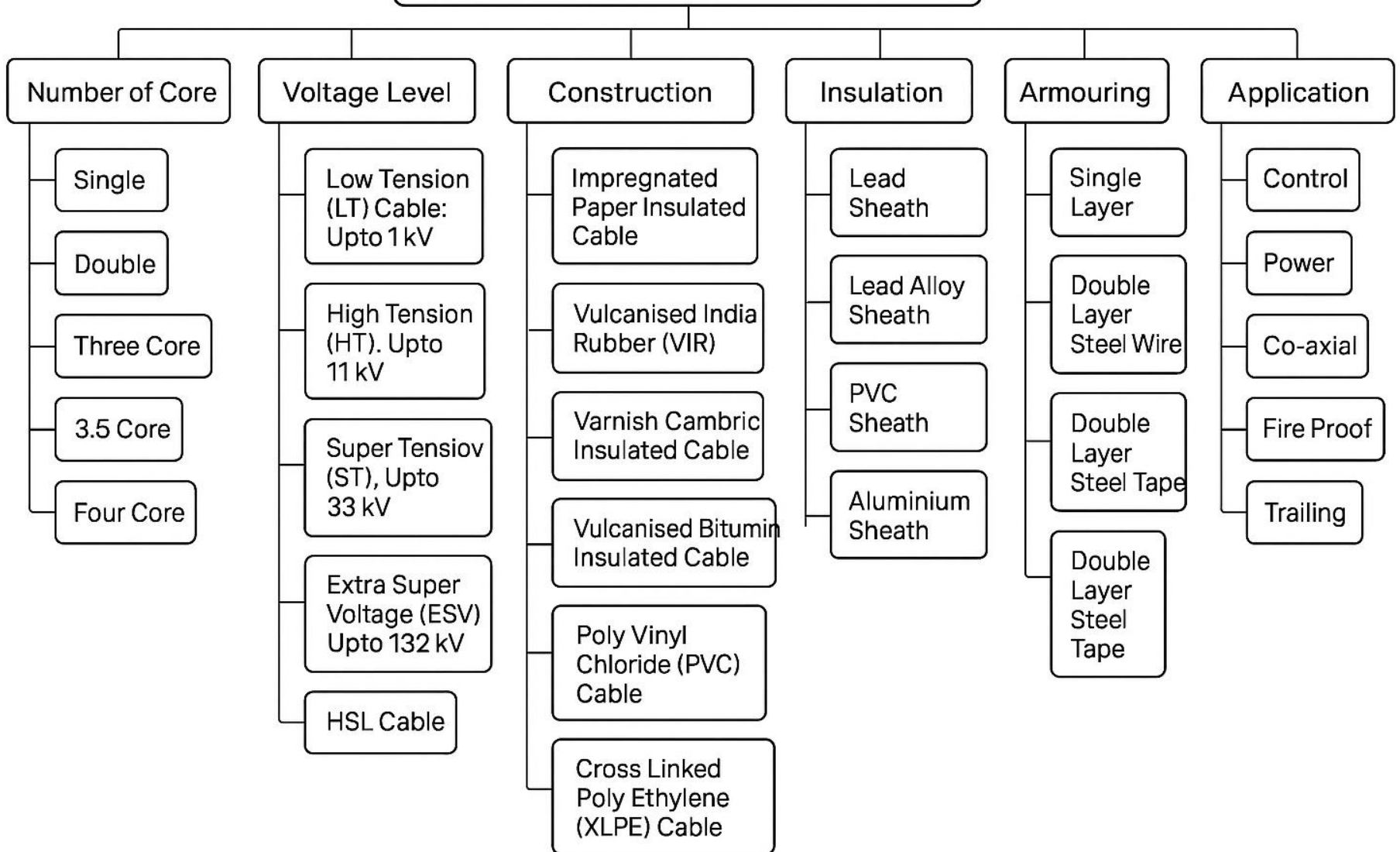

Low Tension (L.T.) Cables

- **Voltage:** Up to 6.6kV.
- **Insulation:** Impregnated paper (sometimes resin).
- **Structure:**
 - Stranded copper/aluminium conductor
 - Paper insulation
 - Lead sheath
 - Layer of compounded fibrous material
 - Armouring (optional)
 - Outer fibrous covering

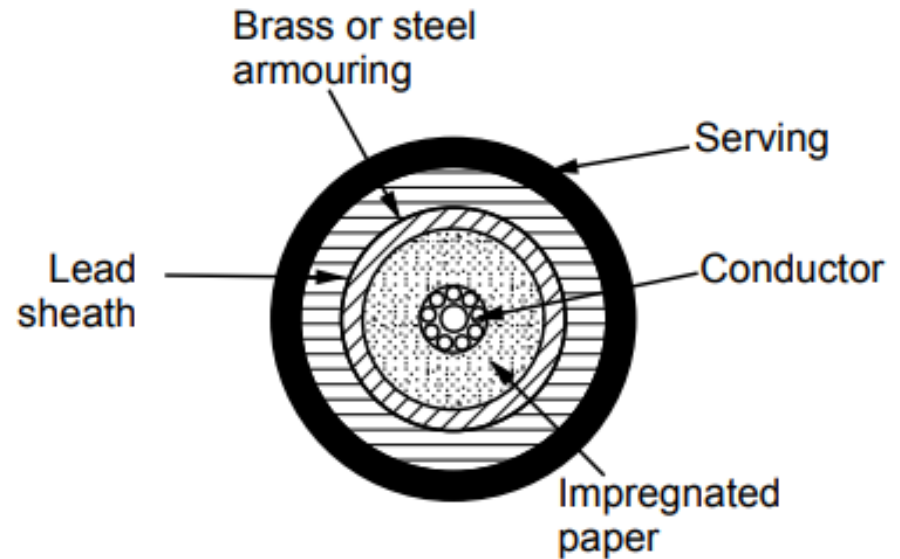

Features: Simple construction, more copper section, often *no armouring*.

Medium & High Tension (H.T.) Cables

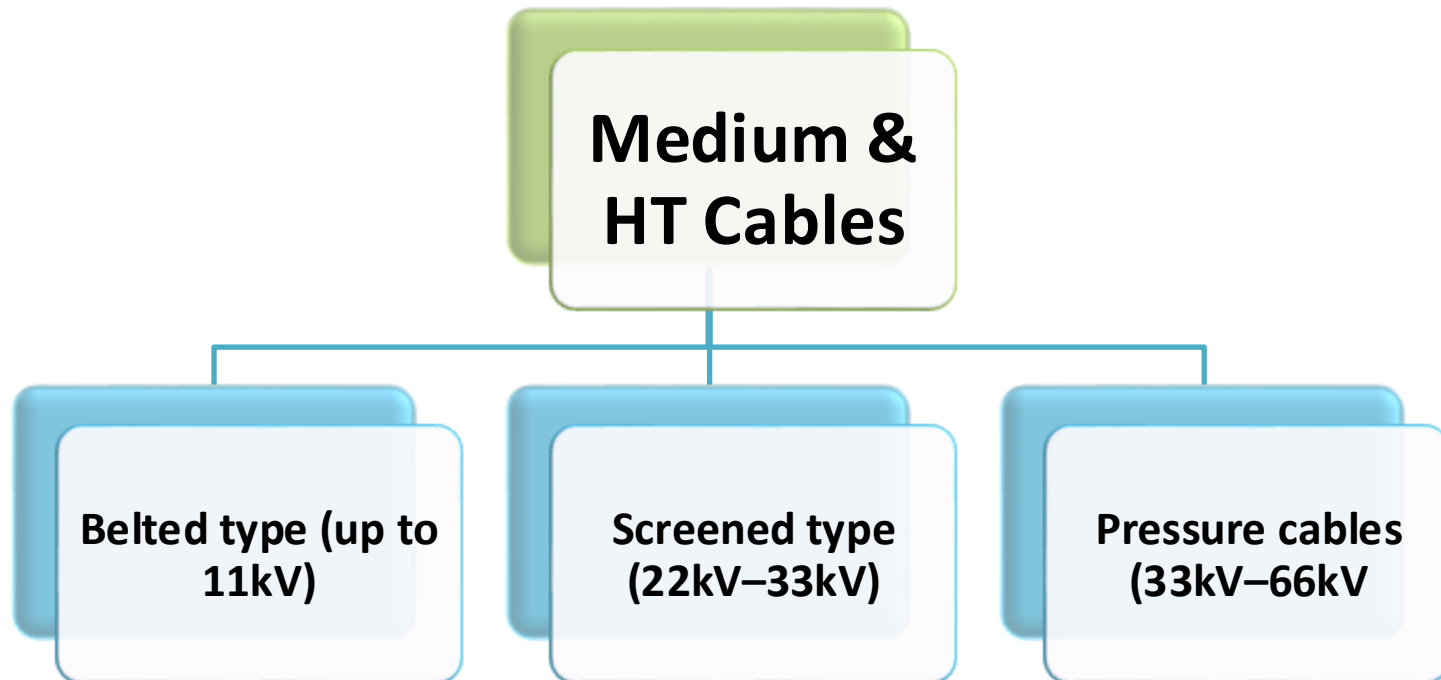

Belted Cables (up to 11kV)

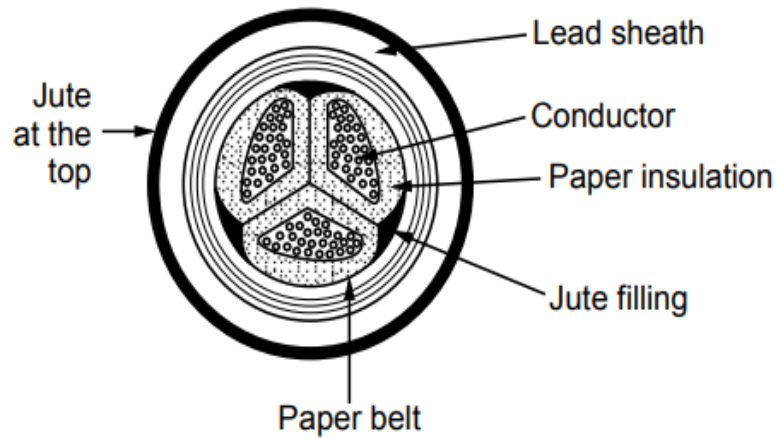

- **Structure:**

- Non-circular cores
- Impregnated paper insulation between cores
- Paper belt for grouping
- Gaps filled with jute
- Lead sheath for moisture/mechanical strength
- Outer fibrous covering

- **Limitations:**

Susceptible to void formation under high voltages due to tangential stresses, wrinkles, and possible gaps when bent

Screened (Solid Type) Cables

H-Type

- **Features:**
 - Each conductor insulated with paper, covered with metallic screen (aluminium foil)
 - Metallic screens touch each other
 - Three cores wrapped with conducting belt
 - Lead sheath, bedding, armouring, serving
- All screens and sheath at earth potential—radial stress, minimized dielectric losses, improved heat dissipation.

S.L. Type (Separate Lead Screened)

- **Features:**
 - Each core insulated and covered by individual lead sheath
 - Cotton tape and filler for grouping
 - No common lead sheath—easier bending, minimized core-to-core faults
- Good dielectric properties, increased current capacity due to individual metal sheaths.

Limitations of Solid Type Cables

- Expansion and contraction can lead to voids
- Void formation can cause insulation breakdown
- Limited to use up to 66kV

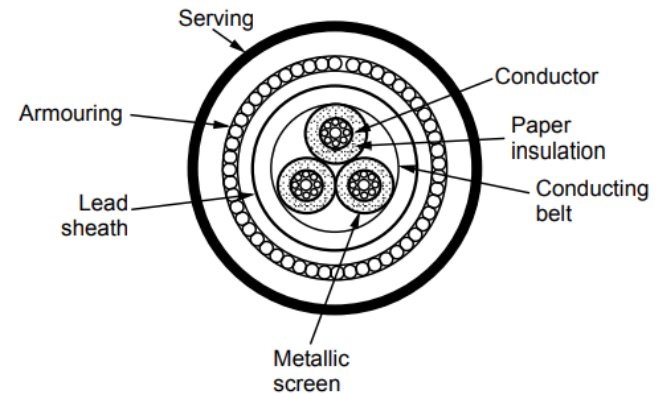
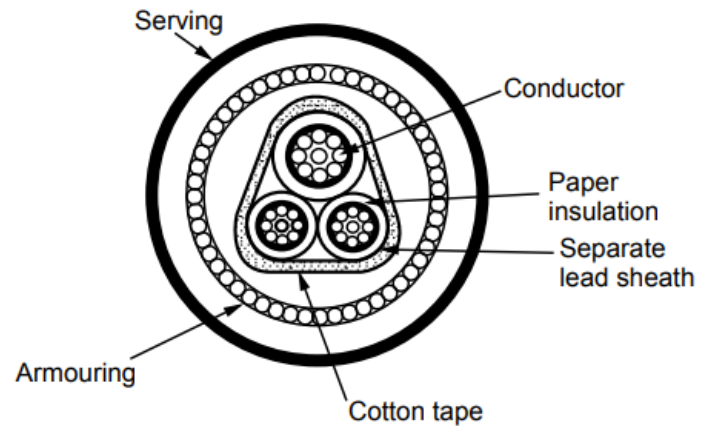

Super Tension (S.T.) & Pressure Cables

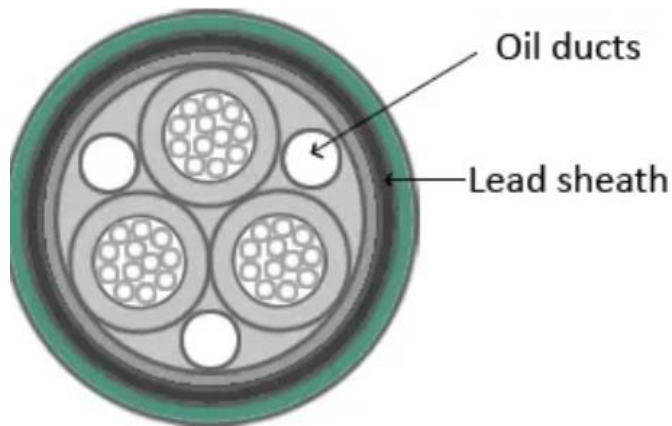
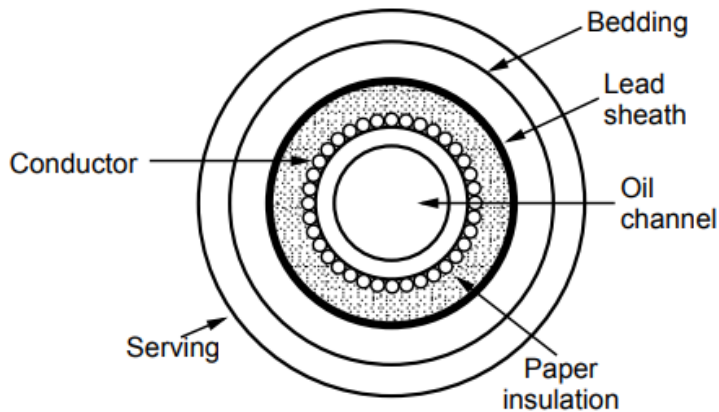

Oil Filled Cables(Used for 132kV–275kV)

- Oil under pressure impregnates insulation
- Oil channels within/adjacent to cores
- Single core & sheath channel designs
- Shielded construction for three-core
- **Advantages:** Less insulation thickness, higher current capacity, void elimination, reduced earth fault chance
- **Disadvantages:** High initial cost, limited length, oil leakage risk, complex installation and maintenance.

Super Tension (S.T.) & Pressure Cables

Gas Pressure Cables (Used for 132kV–275kV)

- Oil under pressure impregnates insulation
- Oil channels within/adjacent to cores
- Single core & sheath channel designs
- Shielded construction for three-core
- **Advantages:**
 - Carries higher load/voltage, low maintenance, improved power factor, easy laying, effective fire quenching
- **Disadvantages:**
 - Very high initial cost

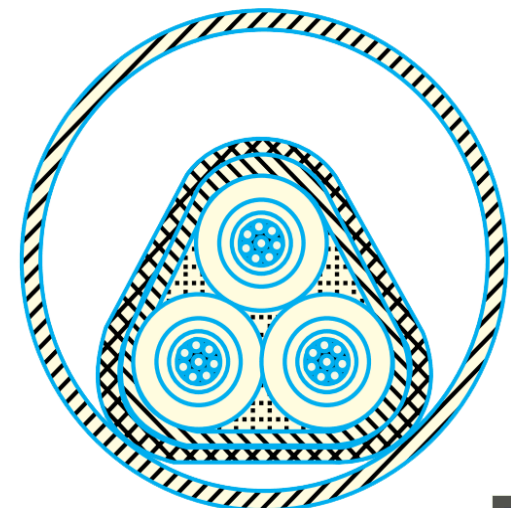
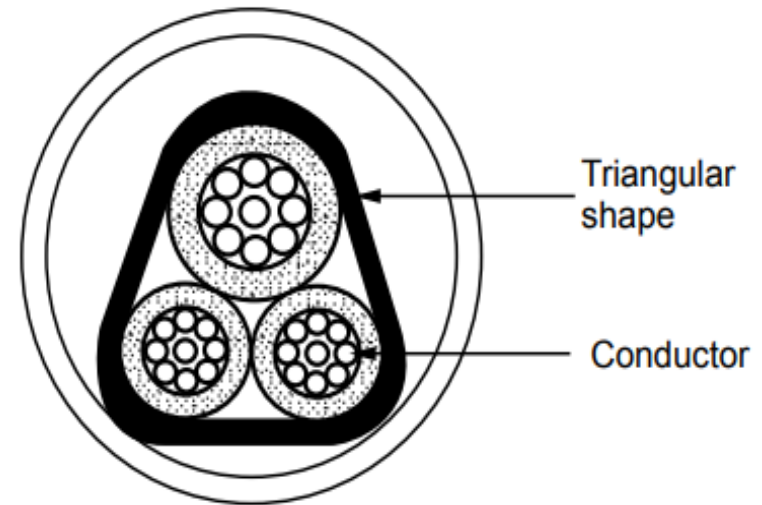

Cable Summary

Cable Type	Voltage Range	Insulation Material	Key Features	Limitations
L.T. Cable	Up to 6.6kV	Paper/Resin	Simple, optional armouring	Not for severe stresses
Belted Cable	up to 11kV	Paper	Belted, grouped cores	Void formation, wrinkles
H-Type Cable	22-33kV	Paper/Metal Screens	Radial stress, good heat diss.	Only up to 66kV
S.L. Cable	22-33kV	Paper/Lead Sheath	Flexible, good insulation	Only up to 66kV
Oil Filled Cable	132-275kV	Oil impregnated	Void-free, higher capacity	Expensive, short lengths
Gas Pressure Cable	132-275kV+	Nitrogen/SF6	Highest voltage, fire safe	Costly

Cable Laying Methods

Direct Laying

Draw in System(Duct/Pipe)

Solid System

Racking on Wall/Overhead
Structure

Racking in Tunnel



Direct Laying

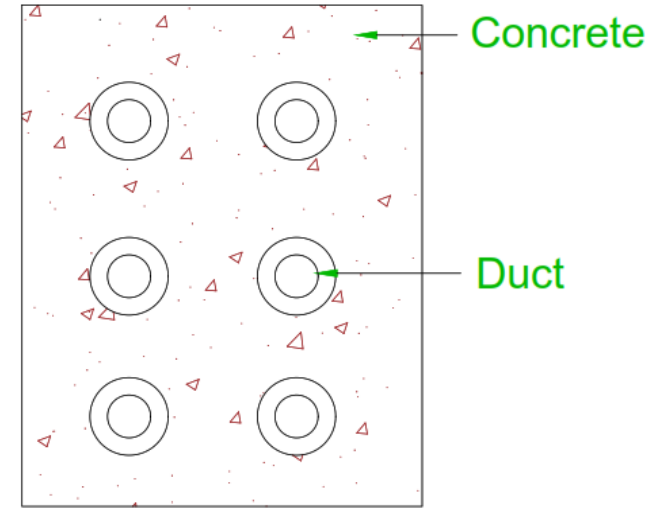

Draw in System(Duct/Pipe)



Racking in Tunnel



Racking on Wall/Overhead Structure

Cable Laying Methods

Direct Laying

Draw in System(Duct/Pipe)

Solid System

Racking on Wall/Overhead
Structure

Racking in Tunnel

Comparision - Cable Laying Methods

No.	Points	Direct Laying	Draw in System	Solid System	Racking on Wall	Racking in Tunnel
1	Current Carrying Capacity	Very Good	Poor	Poor	Good	Medium (If good ventilation is provided)
2	Initial Cost of laying	Low	High	High	Medium	Very High
3	Repairing and Maintenance Cost	Very High	High	High	Medium	Low
4	Time Requirement for Locating a Fault	High	Very High	Very High	Less	Less
5	Possibility of Mechanical Damage	Higher	Less	Medium	Very Less	Less
6	Cable Replacement Cost due to Growth in Demand	High	Medium	Medium	Low	Very Low

Cable Jointing

Heat-shrink



Cold-shrink



Resin Joint



Mechanical
Jointing

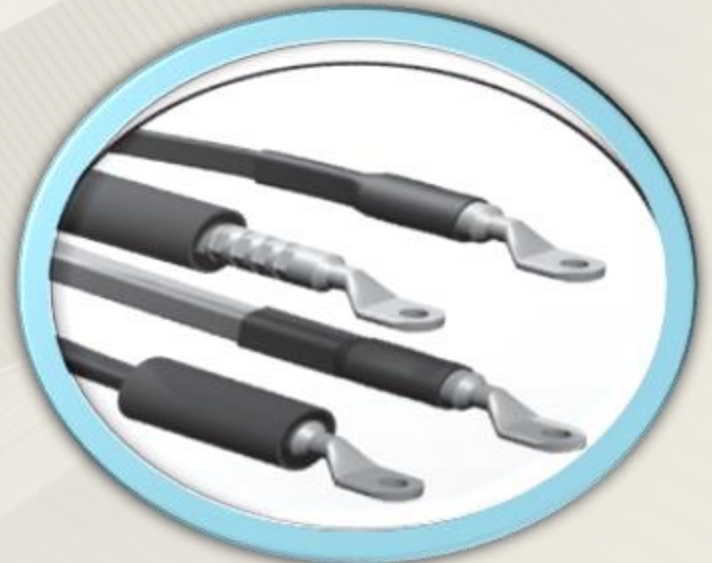

Cable Recycling Process Flow

Collection

- Collect scrap from construction, demolition, or electrical works.
- Sort by type (copper, aluminum, mixed)

Stripping

- Remove insulation using mechanical stripping machines or manual stripping

Shredding

- Cut cables into small pieces for easier separation

Separation

- Use air separation, vibration tables, or water-based systems to separate metals from insulation

Purification

- Remove impurities for high-purity copper/aluminum recovery

Recovery

- Copper, Aluminum → sold to smelters.
- Plastics → recycled for PVC products

Thank You

Vishal D Devdhar
Lecturer
Electrical Engineering Department
Government Polytechnic Rajkot
www.vishaldevdhar.org